



Since 1971

SLICERS 300-350 BLADE CORTADORAS CUCHILLA 300-350



L 300 G - L 300 COM
L 350 G - L 350 COM VV
L 350 GA SEMI-AUTO
L 350 C

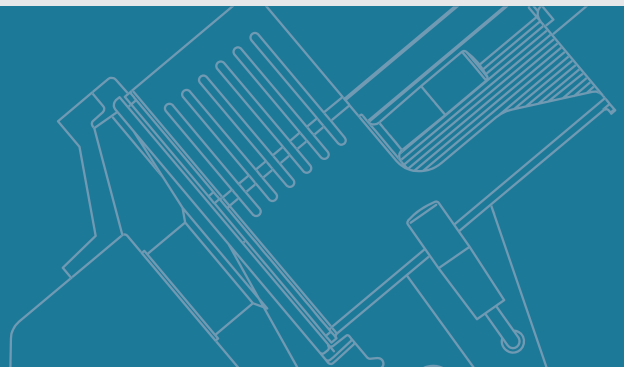



L 300 G

Gravity slicer
Cortadora gravedad



L 300 COM

Gravity semi-auto slicer
Cortadora gravedad semi-auto



1 SPEED / 1 STROKE
40 CUTS/MIN
1 VELOCIDAD / 1 RECORRIDO
40 CORTES/MIN



STANDARD EQUIPMENT

- Belt transmission
- Integrated sharpener friendly use
- 3rd generation blade
- IP69 switches: water-proof and life time warranty
- Aluminium handle
- Removable pusher - easy cleaning
- Product guide to keep the product stable

EQUIPAMIENTO ESTANDAR

- Transmisión por correa
- Afiladora integrada de uso fácil
- Cuchilla de 3^o generación
- Interruptores IP69: a prueba de agua
- Manijas de aluminio
- Prensa producto extraíble de fácil limpieza
- Guía de productos para mantener el producto estable



L 350 G

Gravity slicer
Cortadora gravedad



L 350 COM VV

Gravity semi-auto slicer
Cortadora gravedad semi-auto



TILTING DEVICE (L 350 G ONLY)
DISPOSITIVO DE INCLINACIÓN (L 350 G ONLY)



VARIABLE SPEED / 1 STROKE

0-55 CUTS/MIN
(L 350 COM VV ONLY)

VELOCIDAD VARIABLE / 1 RECORRIDO
0-55 CORTES/MIN
(SOLO L 350 COM VV)



STANDARD EQUIPMENT

- Belt transmission
- Integrated sharpener friendly use
- 3rd generation blade
- Tilting device for L 350 G
- IP69 switches: water-proof and life time warranty
- Aluminium handle
- Removable pusher - easy cleaning
- Product guide to keep the product stable

EQUIPAMIENTO ESTANDAR

- Transmisión por correa
- Afiladora integrada de uso fácil
- Cuchilla de 3º generación
- Dispositivo de inclinación para L 350 G
- Interruptores IP69: a prueba de agua
- Manijas de aluminio
- Prensa producto extraíble de fácil limpieza
- Guía de productos para mantener el producto estable



L 350 GA

Gravity semi-auto slicer
Cortadora gravedad semi-auto



OPTIONAL
VARIABLE SPEED CONVEYOR BELT
CINTA TRANSPORTADORA DE VELOCIDAD VARIABLE



OPTIONAL
EXTRA LARGE MEAT PLATE HOLDER
PLATO EXTRA GRANDE PARA CARNE



STANDARD EQUIPMENT

- Belt transmission
- Integrated sharpener friendly use
- 3rd generation blade
- 10 carriage speed / 3 strokes length (small, medium, large)
- 0-50 cuts/min
- IP69 water-proof control panel life time warranty
- Setup counter
- Aluminium handles
- Removable pusher - easy cleaning
- Product guide to keep the product stable
- Tilting device

EQUIPAMIENTO ESTANDAR

- Transmisión por correa
- Afiladora integrada de uso fácil
- Cuchilla de 3^o generación
- 10 velocidades / 3 recorridos (small, medium, large)
- 0 - 50 cortes/min
- Interruptores IP69: a prueba de agua
- Configuración contador
- Manijas de aluminio
- Prensa producto extraíble de fácil limpieza
- Guía de productos para mantener el producto estable
- Dispositivo de inclinación



L 350 C

Fresh meat slicer
Cortadora de carne fresca

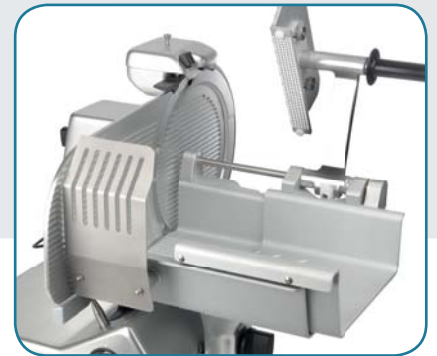

STANDARD EQUIPMENT

- Belt transmission
- Integrated sharpener friendly use
- 3rd generation blade
- Removable product tray with sliding plate
- Tilting product pusher
- Removable pusher - easy cleaning
- IP69 switches: water-proof and life time warranty
- Aluminium handles

EQUIPAMIENTO ESTANDAR

- *Transmisión por correa*
- *Afiladora integrada de uso fácil*
- *Cuchilla de 3ª generación*
- *Bandeja de producto extraíble con placa deslizante*
- *Interruptores IP69: a prueba de agua*
- *Manijas de aluminio*
- *Prensa producto extraíble de fácil limpieza*
- *Guía de productos para mantener el producto estable*

L 300 G

DIMENSIONS AND FEATURES / DIMENSIONES Y CARACTERÍSTICAS

CUTTING CAPACITY - CAPACIDAD DE CORTE

Rectangular □	<i>Rectangular</i>	8.66 x 7,08 in
Square □	<i>Cuadrado</i>	7,08 x 7,08 in
Round Diam. ∅	<i>Diametro circulo</i>	7,87 in
Max Thickness ▲	<i>Apertura máxima</i>	0,59 in

TECHNICAL SPECIFICATION - ESPECIFICACIÓN TÉCNICA

Motor	<i>Motor</i>	0,37 hp - 0,27 kw
Waterproof	<i>Impermeabilidad</i>	IP54
Net/gros weight	<i>Peso neto/gros</i>	69,4 / 80,4 lb
Package sizes	<i>Tamaño embalaje</i>	27,16 x 27,95 x 25,19 in

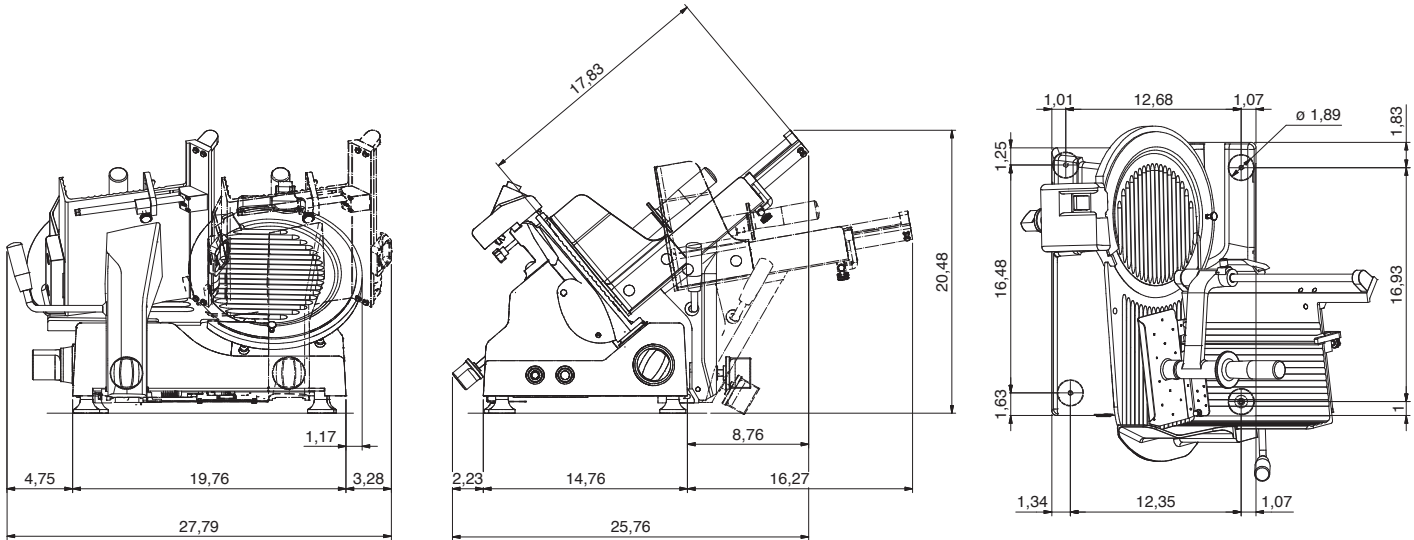

L 300 COM

DIMENSIONS AND FEATURES / DIMENSIONES Y CARACTERÍSTICAS

CUTTING CAPACITY - CAPACIDAD DE CORTE

Rectangular □	<i>Rectangular</i>	8.66 x 7,08 in
Square □	<i>Cuadrado</i>	7,08 x 7,08 in
Round Diam. ∅	<i>Diametro circulo</i>	7,87 in
Max Thickness ▲	<i>Apertura máxima</i>	0,59 in

TECHNICAL SPECIFICATION / ESPECIFICACIÓN TÉCNICA

Motor	<i>Motor</i>	0,37 hp - 0,27 kw
Waterproof	<i>Impermeabilidad</i>	IP54
Cutting speed	<i>Velocidad de corte</i>	Fixed 40 pcs
Net/gros weight	<i>Peso neto/gros</i>	94,7 / 132,2 lb
Package sizes	<i>Tamaño embalaje</i>	27,55 x 27,95 x 32,6 in

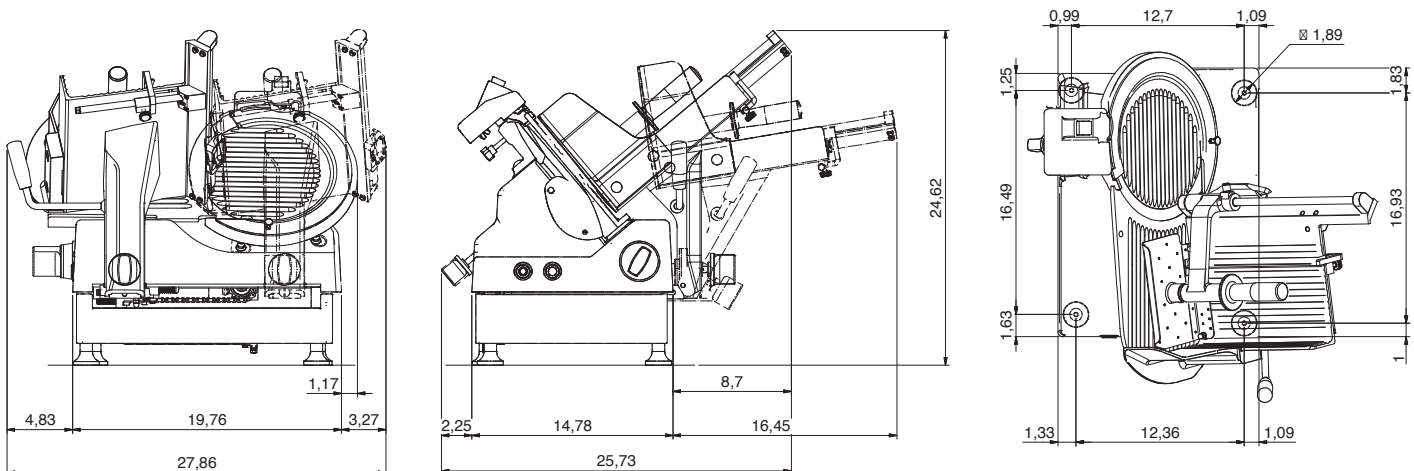

L 350 G

DIMENSIONS AND FEATURES / DIMENSIONES Y CARACTERÍSTICAS

CUTTING CAPACITY - CAPACIDAD DE CORTE

Rectangular □	<i>Rectangular</i>	10,23 x 6,10 in
Square □	<i>Cuadrado</i>	7,87 x 7,87 in
Round Diam. ∅	<i>Diametro circulo</i>	8,66 in
Max Thickness ∆	<i>Apertura máxima</i>	1,18 in

TECHNICAL SPECIFICATION - ESPECIFICACIÓN TÉCNICA

Motor	<i>Motor</i>	0,5 hp - 0,37 kw
Waterproof	<i>Impermeabilidad</i>	IP69
Net/gros weight	<i>Peso neto/gros</i>	88,8 / 101,4 lb
Package sizes	<i>Tamaño embalaje</i>	31,49 x 3,03 x 27,95 in

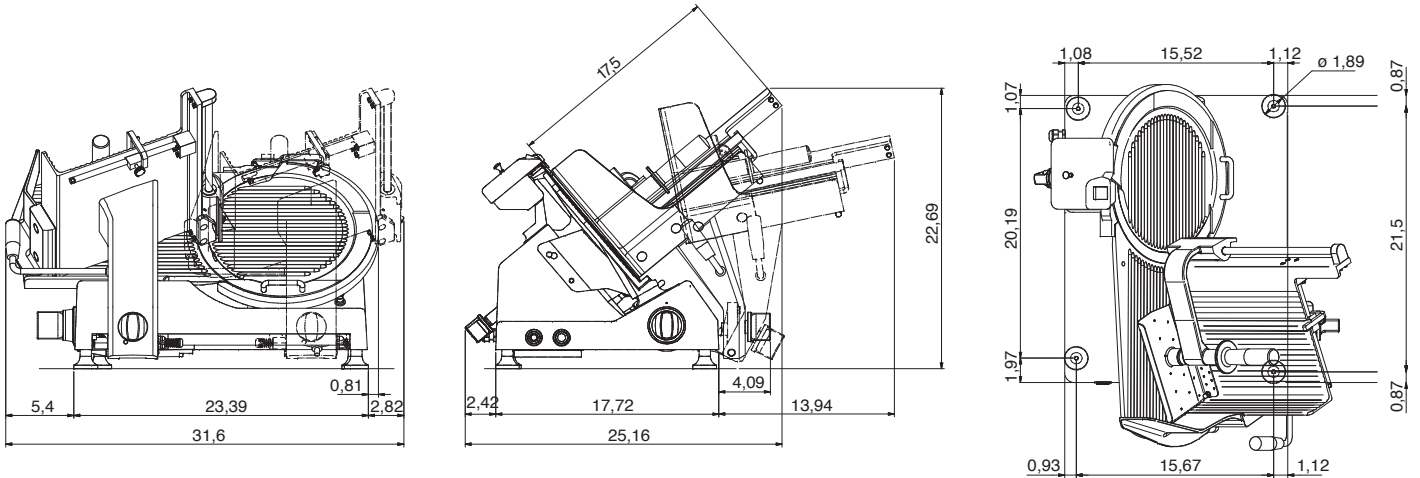

L 350 COM VV

DIMENSIONS AND FEATURES / DIMENSIONES Y CARACTERÍSTICAS

CUTTING CAPACITY - CAPACIDAD DE CORTE

Rectangular □	<i>Rectangular</i>	10,23 x 6,10 in
Square □	<i>Cuadrado</i>	7,87 x 7,87 in
Round Diam. ∅	<i>Diametro circulo</i>	8,66 in
Max Thickness ∆	<i>Apertura máxima</i>	1,18 in

TECHNICAL SPECIFICATION - ESPECIFICACIÓN TÉCNICA

Motor	<i>Motor</i>	0,5 hp - 0,37 kw
Waterproof	<i>Impermeabilidad</i>	IP69
Cutting speed	<i>Velocidad de corte</i>	Variable 0-40 pcs
Net/gros weight	<i>Peso neto/gros</i>	110,2 / 154,3 lb
Package sizes	<i>Tamaño embalaje</i>	29,92 x 31,49 x 32,67 in

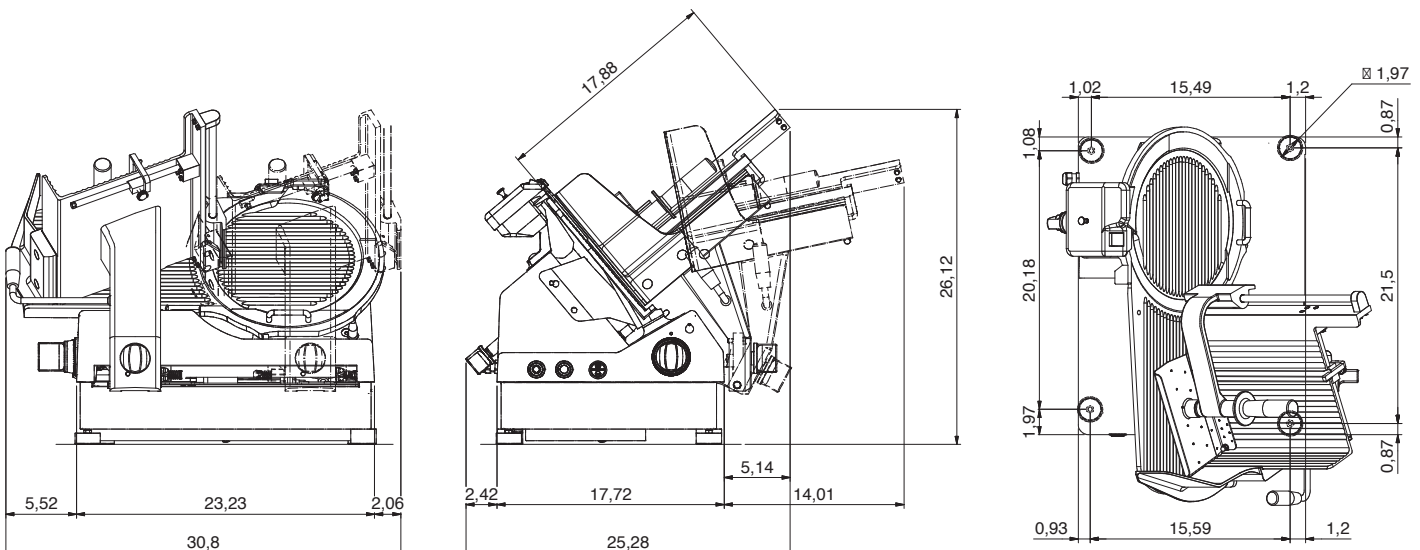

L 350 GA

DIMENSIONS AND FEATURES / DIMENSIONES Y CARACTERÍSTICAS

CUTTING CAPACITY - CAPACIDAD DE CORTE

Rectangular <input type="checkbox"/>	<i>Rectangular</i>	10,23 x 6,10 in
Square <input type="checkbox"/>	<i>Cuadrado</i>	7,87 x 7,87 in
Round Diam. \varnothing	<i>Diametro circulo</i>	8,66 in
Max Thickness \triangleleft	<i>Apertura máxima</i>	1,18 in

TECHNICAL SPECIFICATION - ESPECIFICACIÓN TÉCNICA

Motor	<i>Motor</i>	0,5 hp - 0,37 kw
Waterproof	<i>Impermeabilidad</i>	IP69
Cutting speed	<i>Velocidad de corte</i>	Variable 20-50 pcs
Net/gros weight	<i>Peso neto/gros</i>	108 / 132,2 lb
Package sizes	<i>Tamaño embalaje</i>	29,92 x 31,4 x 32,6 in

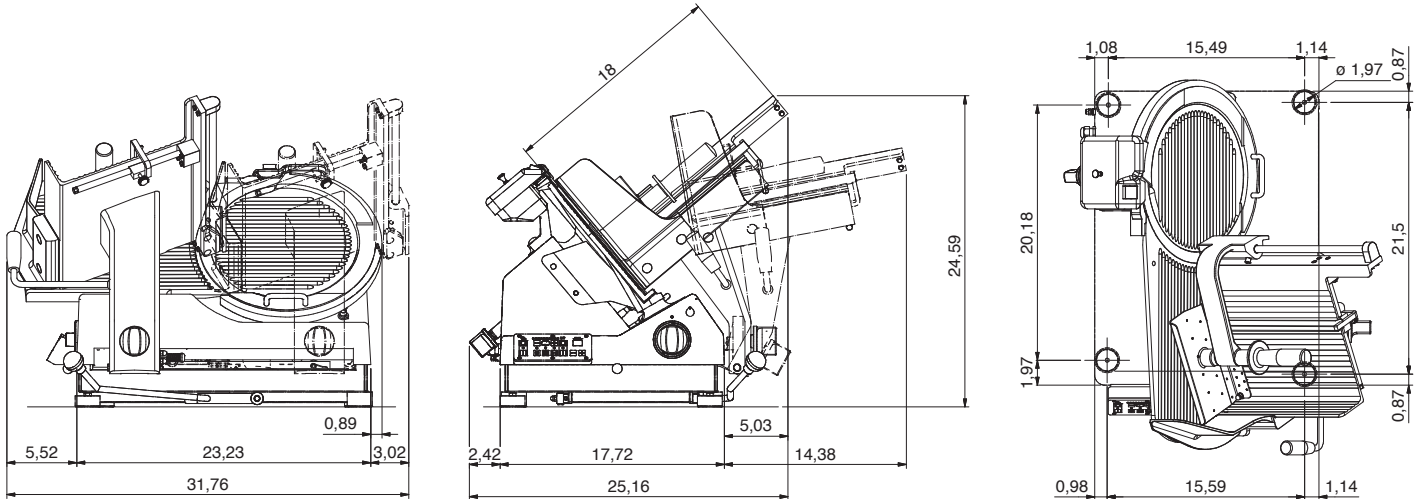

L 350 C

DIMENSIONS AND FEATURES / DIMENSIONES Y CARACTERÍSTICAS

CUTTING CAPACITY

Rectangular <input type="checkbox"/>	<i>Rectangular</i>	11,41 x 10,23 in
Square <input type="checkbox"/>	<i>Cuadrado</i>	10,23 x 10,23 in
Round Diam. \varnothing	<i>Diametro circulo</i>	10,23 in
Max Thickness \triangleleft	<i>Apertura máxima</i>	0,78 in

TECHNICAL SPECIFICATION - ESPECIFICACIÓN TÉCNICA

Motor	<i>Motor</i>	0,37 hp - 0,27 kw
Waterproof	<i>Impermeabilidad</i>	IP69
Net/gros weight	<i>Peso neto/gros</i>	102 / 114,6 lb
Package sizes	<i>Tamaño embalaje</i>	31,49 x 30,31 x 27,95 in

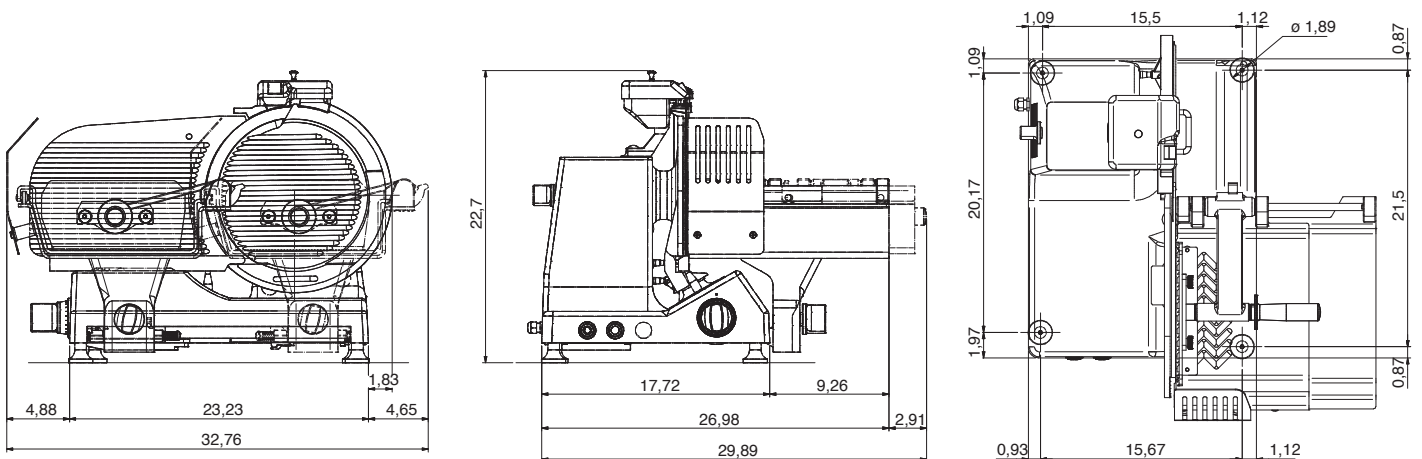

Since 1971

2308 17th Ave - Franklin Park, IL 60131
T. 847 451 9727 - abmusa@abmslicers.com

www.abmslicers.com