



Digital Industrial Bowl Cutters / Choppers



K120neo • K200neo

Market Leader in the Global Food Industry



Boost your productivity with more capacity and advanced features.

Outstanding features



The **Talsa K120neo and K200neo** cutters are designed for the production of sausage hash of all kinds, for large slaughterhouses and industrial meat processors.

They are also suitable for a wide range of poultry, fish, pastry or vegetarian products, processed cheese and many commodities in the food processing industry.

The K120neo and K200neo cut, mix and emulsify all types of food products, from thick to very fine textures. They are simple to use, have an automated control system and are cleaned and maintained with ease.



Talsa Control

- ✓ Modern 10-inch touch screen.
- ✓ 10 membrane buttons for the most used functions.
- ✓ Digital display indicating gear, blade speed, temperature, turns, elapsed time, current time.
- ✓ Automatic stop (time elapsed, temperature, turns of the bowl).
- ✓ Display maintenance and service intervals.

Optional:

- ✓ Interactive recipe guide.
- ✓ User administration.
- ✓ Data recording.
- ✓ Production plan.

Innovative design

R&D project on vibration and sound reduction in cooperation with the Polytechnic University of Valencia, Mechanical Engineering Research Centre:

- ✓ Fully 3D computer modelling designed.
- ✓ Vibration reduction on the knife shaft.
- ✓ Reduction of noise and vibration in the chassis.
- ✓ Silent drive transmission.

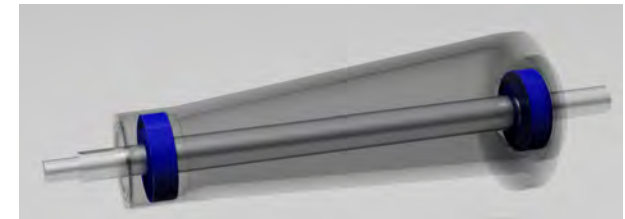

Advantages at a glance



- Detachable 6 - knife head and compensation rings for use with 3 knives.
- High-quality knives from BE-GW Steffens (Germany), adjustable to minimum distance to bowl.
- Optimized cavity design uses bottom of the stainless steel lid to also cut.
- Temperature sensor (°F/°C) located in the cutting cavity for precise measurement of product temperature in friction.
- Knife shaft designed with dynamic 3D modelling to achieve further reduction of vibrations.

- Bowl capacity K200: up to ±160 kg soft meat or ±100 kg dogged/frozen meat (K120: ±90 / ±60 kg).
- Recommended option: hydraulic loader for standard 200 liter trolleys and motorized hydraulic unloading arm to empty to trolley.
- Optional for K120neo: manual unloading arm with motorized disc.
- Motorized stainless steel knife lid for effortless lifting and lowering.
- Noise protection plastic cover with CE safety clearance of the knife speed when opening and returning to the previous speed when closing.

- 100% stainless steel AISI304 (K200).
- Very solid construction. Strong machine frame.
- Solid bowl made of robust stainless steel cast, with liquid drain plug.
- Adjustable NGI Denmark feet, non-slip and vibration absorbing.



- IP65 watertight electric cabinet.
- Bearings without maintenance, guaranteed 2 years.
- Polished surfaces, without corners, with CE radius to facilitate cleaning and comply with the highest hygienic requirements.
- Hygienic labyrinth in the knife head to prevent meat dough from entering the shaft / bearings.
- Electronic device to avoid condensation inside the machine.
- Bottom of machine closed with labyrinthine breathing slots.

- Control panel with large 10" digital touch screen and 10 membrane pushbuttons.
- Variable high cutting speed from 1.000 to 4.000 rpm.
- 4 preselectable knife speeds: 1.000, 2.000, 3.000 and 4.000 rpm.
- Variable bowl speed from 6 to 18 rpm, 4 preselectable speeds.
- Slow mixing speed variable from 50 to 200 rpm, forward & reverse.
- 4 preselectable speeds: 50, 100, 150 and 200 rpm.
- Variable mixing bowl speed from 6 to 10 rpm.
- High power to cut compact and even solid frozen meat.
K200n: 82 HP / 60 kW, with PowerPlus option 109 HP / 80 kW.
K120n: 48 HP / 35 kW, with PowerPlus option 82 HP / 60 kW.
- High energy efficiency class IE3 globally, with high performance ABB motors and VDF electronic frequency converters.
- Smooth starts and stops of knives and bowl due to next generation electronic frequency converters.
- Automatic electronic knife safety brake.
- Thermal protection on all motors.
- Standard voltage 400/380 V, other voltages available.

Standard equipment



Knife Head with **6 standard knives**
BE-GW Steffens (Germany).



recommended option

Hydraulic loader for fast and simple filling.
Standard 200 l trolleys.



recommended option

Hydraulic and motorized unloader for emptying the bowl fast and simple.



Stainless steel **motorized knife lid**
for effortless lifting and lowering.



Noise protection cover with automatic decrease of knife speed. With opening to add spices without lifting the cover.

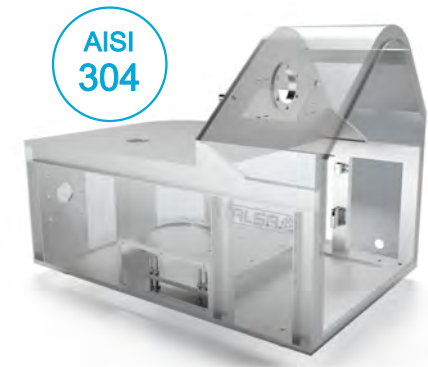

Very solid construction.
Large openings to access the interior.
100% AISI 304 stainless steel (K200).

Standard equipment



Removeable lid/bowl friction band to facilitate cleaning.



Smooth polished surfaces, no corners or screws, with $C\infty$ radius for easy cleaning.



Bowl with drain plug for liquids.



Digital display to control and program all functionalities of the cutter.

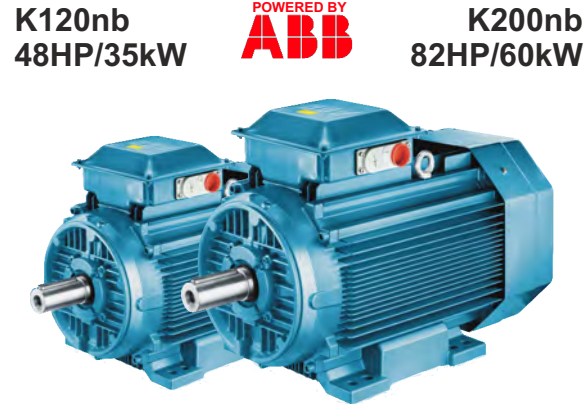

Powerful ABB knife motors for heavy applications.



Talsa Quicklock reduces the time to dismantle and assemble the knives in the knife head.

Optional equipment



More power with **PowerPlus** option!

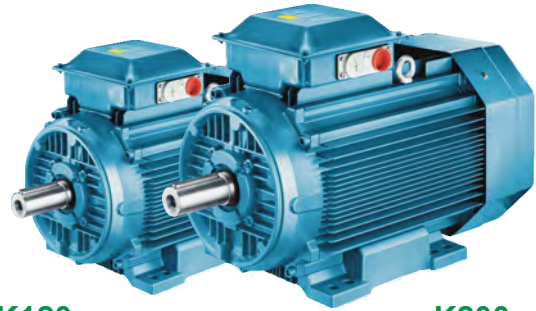

K120npp
82HP/60kW



K200npp
109HP/80kW

More powerful ABB knife motors **POWERPLUS**, especially for extra heavy applications.



Hydraulic loader / unloader, available for K200neo and K120neo.



Motorized unloader disk, only for K120neo.



G & W Steffens knives, best fit for your application:

- Knife UN for raw, cooked and scalded sausage
- Knife EF for extra-fine emulsions
- Knife EX for raw sausage



Talsa Control Plus, allows to extend the functionalities and shedule tasks / recipes.



Euro tub Europa 200 liters, for loader, s/steel AISI304, with wheels and handle, DIN9797

Technical specifications



	K120n	K200n
Bowl capacity	120 litres (32US.liq.gal.)	205 litres (54US.liq.gal.)
Approximate batch size	soft meat	± 20-90 kg (± 44-200lbs)
	dogged meat	± 20-160 kg (± 44-350lbs)
	± 20-60 kg (± 44-132lbs)	± 20-100 kg (± 44-220lbs)
Machine power, standard	35 kW / 48 HP	60 kW / 82 HP
Machine power, PowerPlus optional	60 kW / 82 HP	80 kW / 109 HP
Knife motor, standard	30 kW / 41 HP	55 kW / 75 HP
Knife motor, PowerPlus optional	55 kW / 75 HP	75 kW / 102 HP
Bowl motor	3 kW / 4 HP	3 kW / 4 HP
Hydraulic loader motor	0,74 kW / 1 HP	0,74 kW / 1 HP
Hydr. unloader disc motor	0,37 kW / 0,5 HP	0,37 kW / 0,5 HP
Max. consumption, Standard	380/400 V	60 A
	460/480 V	52 A
	220/230 V	107 A
Max. consumption, PowerPlus	380/400 V	104 A
	460/480 V	85 A
Knife speed cutting	variable	1.000-4.000 rpm
	preselectable	1.000/2.000/3.000/4.000 rpm
Linear knife speed at 4.000 rpm	up to 100 m/s	up to 117 m/s
Bowl speed cutting		6/10/14/18 rpm
Knife speed mixing	variable	50-200 rpm
	preselectable	50/100/150/200 rpm
Bowl speed mixing		6/10 rpm
Speed of unloader disc		130 rpm@50 Hz (156 rpm@60 Hz)
Net weight approx.	±1.500 kg (3,300lbs)	±3.000 kg (6,600lbs.)
Sound pressure level @1m	± 75 dB(A)	± 79 dB(A)
Operating temperature		+5° to +40° C (40° to 105° F)
Relative humidity level		20 to 90 %

Dimensions

K120n K200n

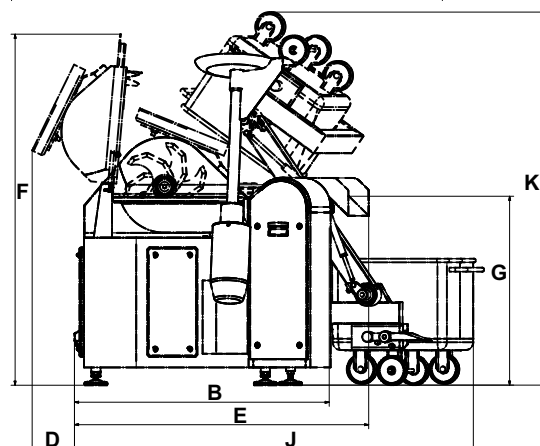
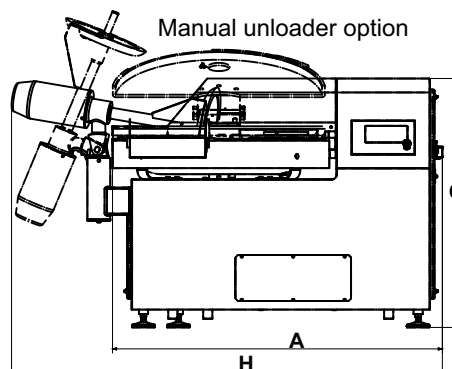
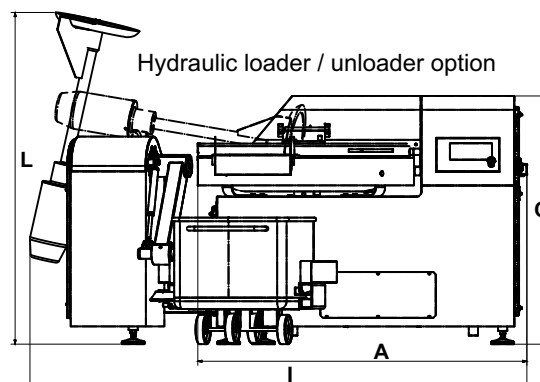

Centimetre

A	180	223
B	139	167
C	136	149
D	23	32
E	161	192
F	192	195
G	103	109
H	235	-
I	272	298
J	218	248
K	204	240
L	181	194

Inch

A	71"	88"
B	55"	66"
C	54"	59"
D	9"	13"
E	64"	76"
F	76"	77"
G	41"	43"
H	93"	-
I	107"	118"
J	86"	98"
K	81"	95"
L	72"	77"

TALSA, Tradition and Innovation:

35 years producing cutters.

115 years of industrial experience in machinery.

Sales and distributors in more than 60 countries.



Four generations of the Belloch family have succeeded in making what began as a small mechanical workshop founded in 1900 to serve the electrical industry, more than 100 years later an efficient industrial structure of 6000m² where attention, illusion and constant improvement is paid to every detail of our machines.

In this catalog we offer you the best of our knowledge and experience and the most modern and innovative machines, newly designed with advanced 3D software technology and R&D support from the European Union.

Thank you for your confidence.



Our product range:

- Cutters/Choppers
- Miners/Grinders
- Fillers/Stuffers
- Mixers
- Cookers/Kettles

Talsabell s.a.
Valencia - Spain
www.talsanet.com



Your authorized TALSA dealer:

Dimensions and illustrations are not binding. We reserve the right to make changes.