

VACUUM MACHINE VA 820820

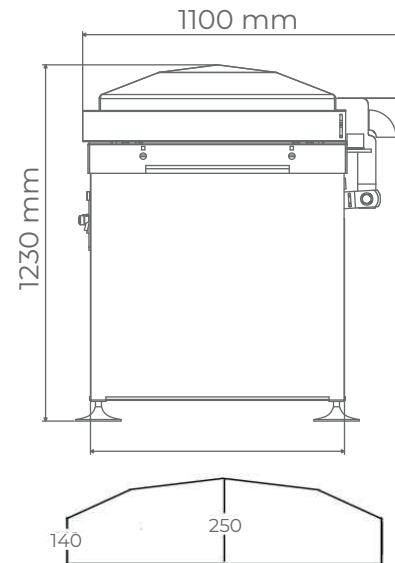

Machine dimensions:
L1865xA1100xH1230

Adjustable working height:
900 mm approx.

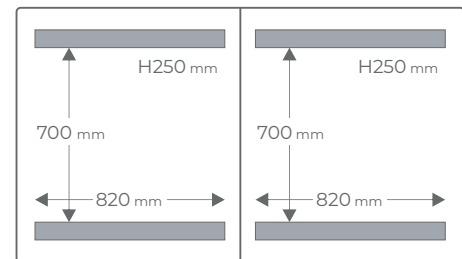

MACHINE SPECIFICATIONS

PUMP	POWER	VOLTAGE	APROX. WEIGHT
100 - 160 - 202 m ³ /h	2,2- 4 - 4,5 kw	400 V - 50/60 Hz 3F+N+T	600 Kg (according to pumps)

OPTIONS

GAS BY % AND BY TIME

HOT WIRE CUTTING OF REMNANT PLASTIC

GENERAL FEATURES

- Digital control board with 25 programmes.
- Made of stainless steel AISI 304.
- Special hygienic design.
- Vacuum % and time.
- Digital counter of working hours.
- SOFT AIR.
- Special sealing for fat, blood, water, etc.
- Easy disassembly of the sealing bars for cleaning.