



## SHRINK TANK ACC 505 - 707 - 909 - 1111 (AUTOMATIC CONTINUOUS HEAT)

**OPERATION:** It shrinks the products by hot air. It heats by electrical heaters.



### WEIGHT

600 Kg. Approx.

### ELECTRICITY

Voltage: 380-400/440-460 V  
THREE-PHASE  
No. of phases: 3+N+G  
Frequency: 50/60 Hz.

Voltage: 220-230 V -  
THREE-PHASE  
No. of phases: 3+G  
Frequency: 50/60 Hz.

9 Electrical heaters of 1600 W  
Maximum power: 18 Kw.

ACC 505 = 1179 mm  
ACC 707 = 1379 mm  
ACC 909 = 1579 mm  
ACC 1111 = 1779 mm

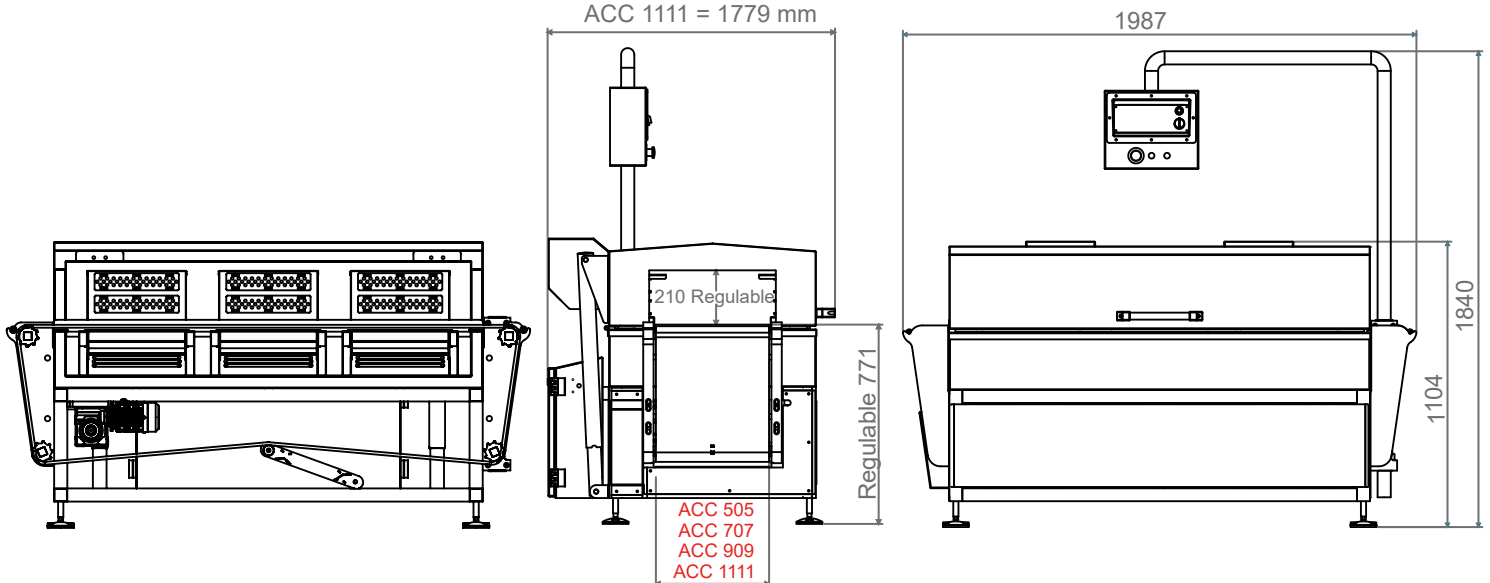

### GENERAL FEATURES

- Built in stainless steel AISI 304.
- CE Certification.
- Motorized conveyor belt with adjustable speed.
- Upper and lower heating with recirculation of hot air.
- Three heating stations.